

WEH®-High-Performance Check valves TVR2



WEH is offering low-cost, high-performance check valves for use with liquid and gaseous media.

The check valve system is designed to minimize the effect that dirt particles have on the components. Due to the sleek, internal aero-dynamic design of the check valve, chatter and flow restriction is greatly reduced.



WEH®-Description of product

Benefits:

- Low cracking pressure
- Quiet in operation
- Seals are protected from the media flow
- Extremely leak-tight
- For use with liquid and gaseous media
- Maintenance free and corrosion resistant
- Special designs

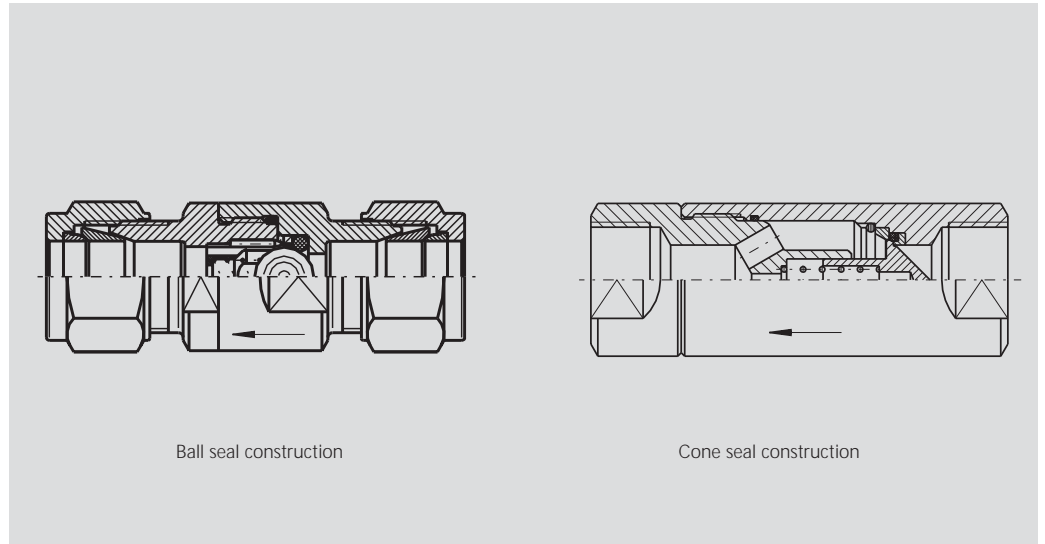

Features:

The check valve system is designed to minimize the effect that dirt particles have on the components. The WEH-Check valves are constructed of high-grade material achieving a very durable unit. Due to the sleek, internal aero-dynamic design of the check valve, chatter is greatly reduced. The high performance sealing system means that the TVR2 is suitable for applications with gaseous media.

Nominal bore:

3 mm up to 50 mm

Cracking pressure:

up to nominal bore 8 mm:
approx. 0.1 bar
up to nominal bore 14 mm:
approx. 0.5 bar.
greater than nominal bore
16 mm: approx. 1 bar.
Other cracking pressures
on request

Design:

All parts stainless steel
(1.4305) corrosion resistant;
up to 8 mm nominal bore
some inner parts brass.
Other materials on request.

Seals:

Standard valve with FKM
seals. NBR, EPDM, PTFE
and others on request.

Temperature:

FKM: -20 °C up to + 140°C,
other temperatures on
request

Application:

WEH-TVR2 check valves
are for use with liquid and
gaseous media.

Note:

Please fill in the enclosed
questionnaire and send it
back to enable us to offer
the check valve for your
specific application.
For special applications and
special valves, please send
enquiry with the ques-
tionnaire indicating the
max. operating pressure,
temperature, cracking
pressure, dimensions etc.



WEH®-Type TVR2

Check valve with
tube connection on both ends

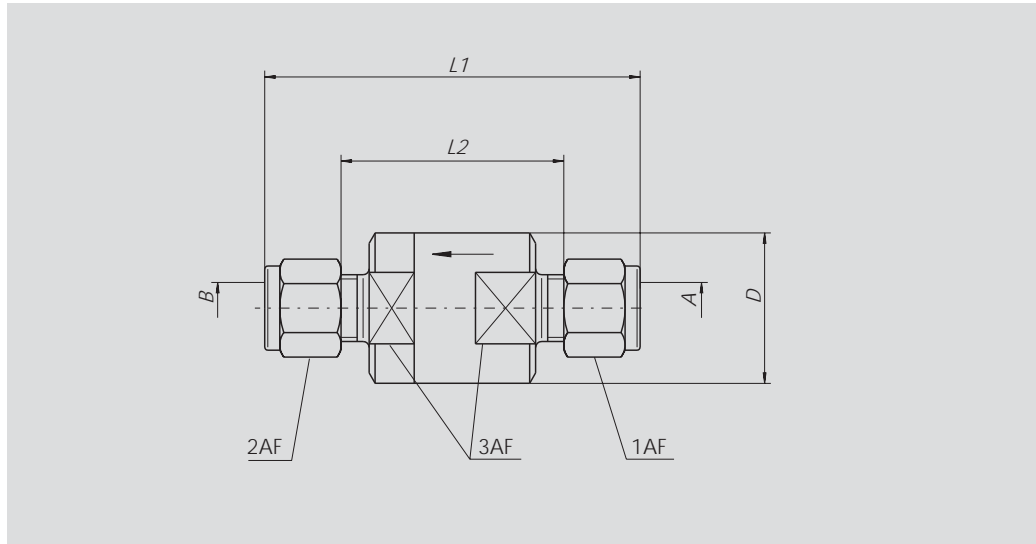

PB (bar)	A / B	L1	L2	D	1AF/2AF	3AF	Body size	Part No.
350	6	64	33,7	25	14	22	8	C20010
	8	64	33,7	25	16	22	8	C20011
	10	64	33,7	25	19	22	8	C20012
	12	70	33,7	25	22	22	8	C20013
	12	110	62,7	35	22	30	12	C20014*
	16	112	62,7	35	25	30	12	C20015*

Dimensions in mm

* Valves with cone seal (not ball)



WEH[®]-Type TVR2

Check valve with
internal thread on both ends

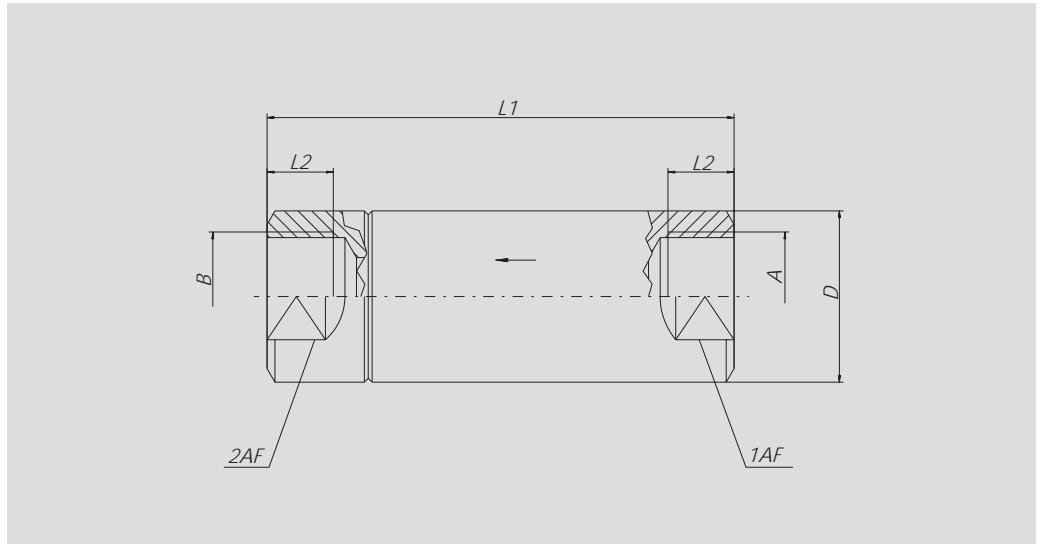

PB (bar)	A / B	L1	L2	D	1AF/2AF	DN nominal bore	Body size	Part No.
400	G 1/8"	52	10	25	14	6	8	C20000
	G 1/4"	52	10	25	14	6	8	C20001
	G 3/8"	95	17	35	14	14	12	C20002*
	G 1/2"	95	17	35	30	14	14	C20003*
	G 3/4"	110	17	39	34	16	16	C20004*
250	G 1"	120	18	48	41	20	20	C20005*
	G 1 1/4"	125	22	60	50	25	25	C20006*
	G 1 1/2"	130	22	65	55	32	32	C20007*
	G 1 1/2"	145	22	69	60	40	40	C20008*
	G 2"	152	24	88	75	50	50	C20009*

Dimensions in mm

* Valves with cone seal (not ball)

WEH[®]-Type TVR2

Flow curves

- These flow curves have been determined to the standard EN 60534 (water).
- The curves relate to unrestricted inlet and outlet.
- The curves relate to cavitation free flow of water.

Q = flow rate

ΔP = drop in pressure

Flow curve
TVR2-NW 6
Kv = 0.6
Cv = 0.7

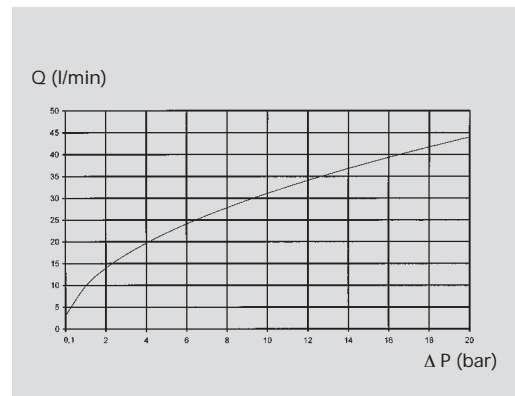
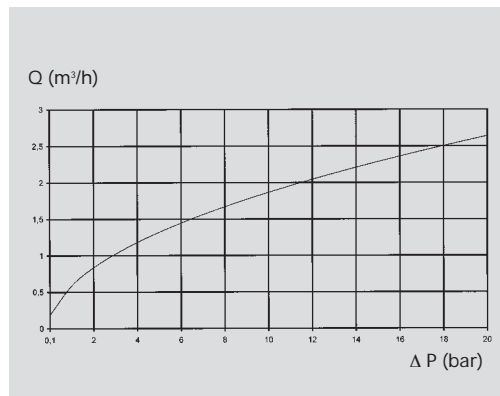

Flow curve
TVR2-NW 8
Kv = 0.81
Cv = 0.95

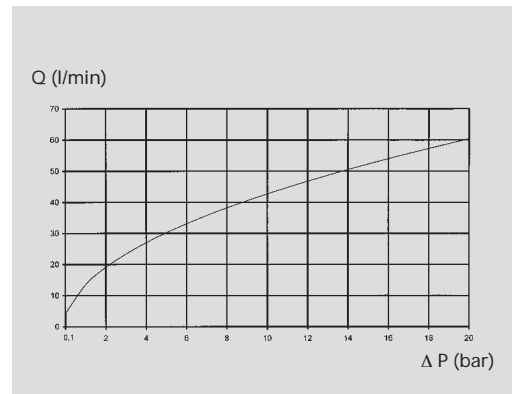
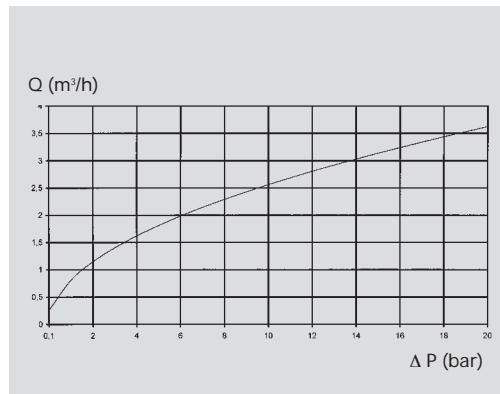

Flow curve
TVR2-NW 10
Kv = 0.98
Cv = 1.14

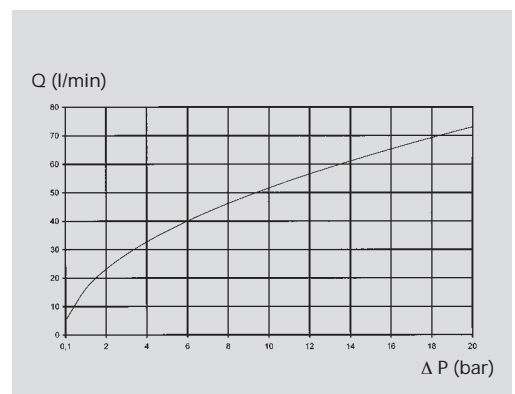
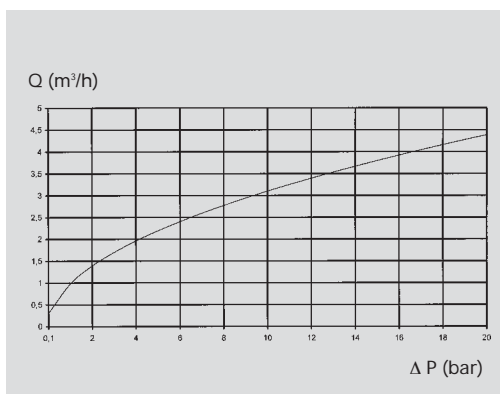



WEH[®]-Type TVR2

Flow curves

Flow curve
TVR2-NW 12
 $K_v = 5.0$
 $C_v = 5.8$

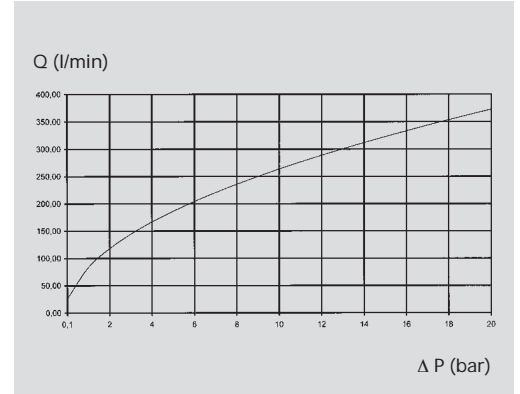
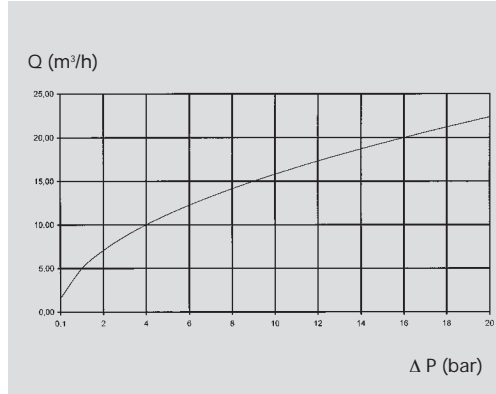

Flow curve
TVR2-NW 16
 $K_v = 7.4$
 $C_v = 8.6$

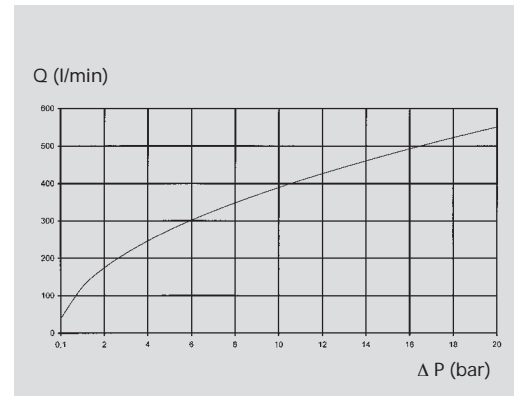
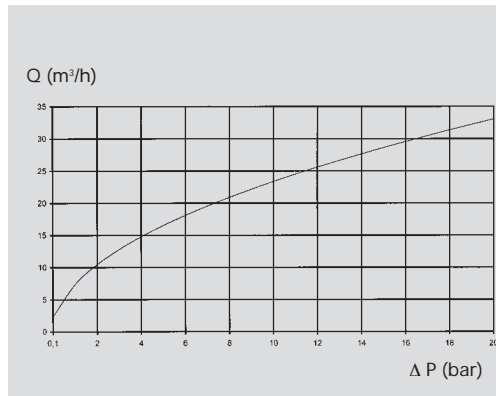

Flow curve
TVR2-NW 20
 $K_v = 10.7$
 $C_v = 12.5$

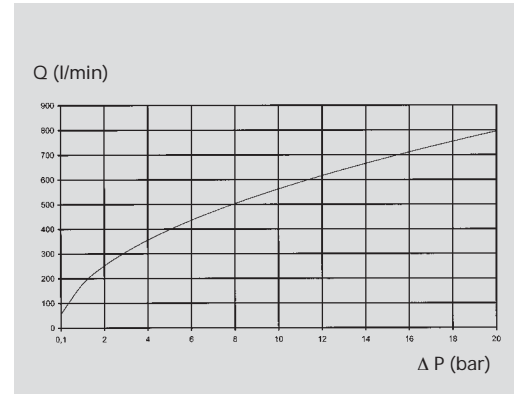
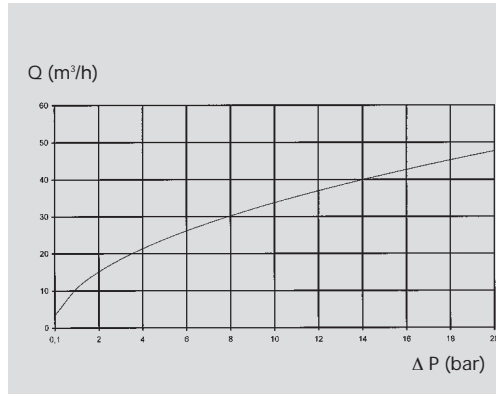

Flow curve
TVR2-NW 25
 $K_v = 14.7$
 $C_v = 17.2$

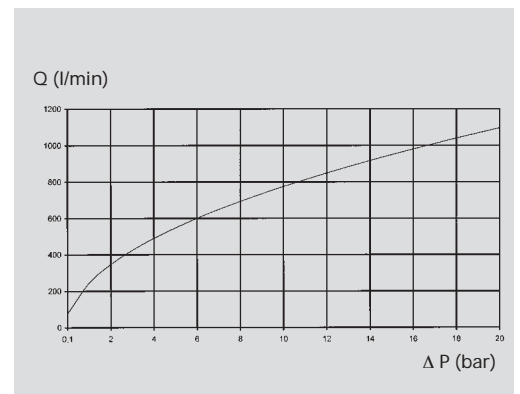
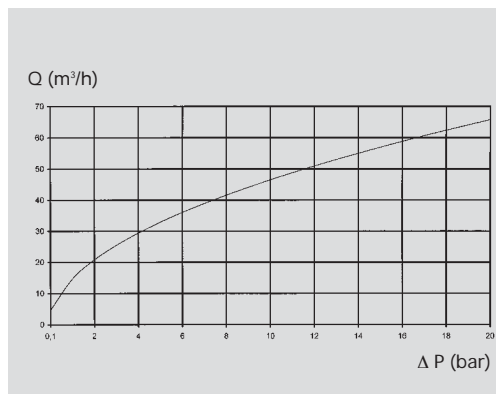



WEH[®]-Type TVR2

Flow curves

Flow curve
TVR2-NW 32
 Kv = 27.8
 Cv = 32.4

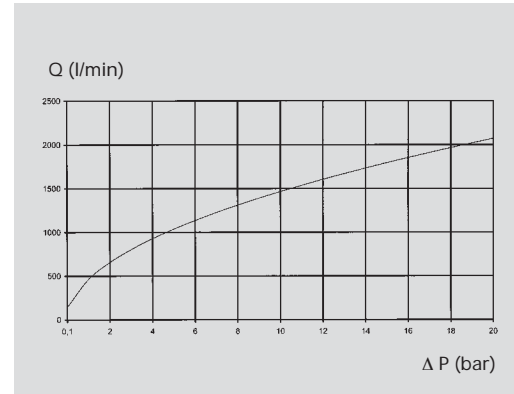
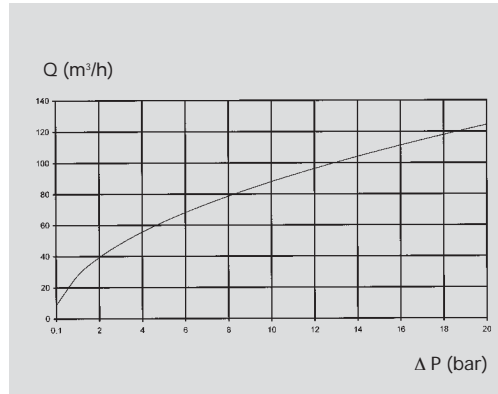

Flow curve
TVR2-NW 40
 Kv = 38.1
 Cv = 44.5

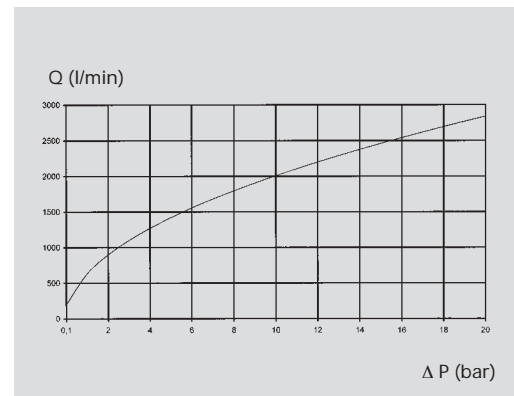
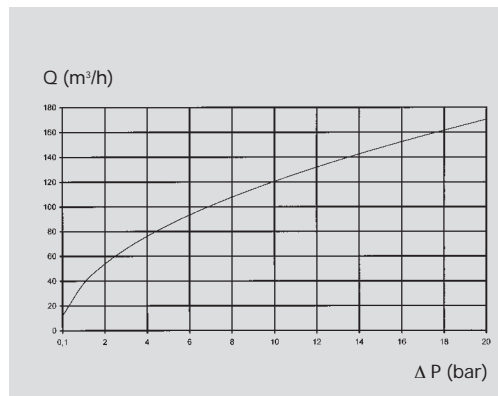

Flow curve
TVR2-NW 50
 Kv = 57.4
 Cv = 67.0

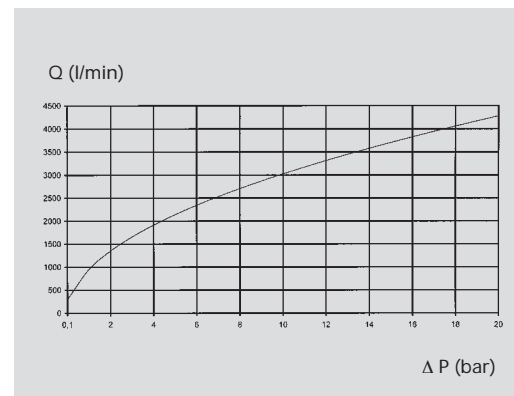
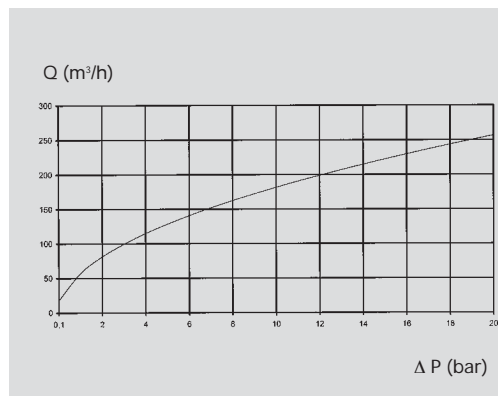

Technical Information

Pressure definition:

Abbreviation	Pressure type	Description/Explanation
PN	Nominal pressure	This is a standardised term
PS	Operating pressure	The max. pressure to which the component is subjected (1.25 x PN)
PT	Test pressure	The pressure to which the component is tested by the manufacturer ('once only' test, 1.43 – 1.5 x PS)
P1, P2, P3	Pilot pressure	For pneumatically actuated connectors. P1 – P3 is normally air pressure.

Admissible operating pressure:

The admissible operating pressure has been determined as follows: 100,000 x cycles impacting the component with 125 % of PN.

The pressure wave is sinusoidal.

Pressure/Temperature:

For higher temperatures the max. operating pressure needs to be reduced dependant on the application. Possible values therefore are: 50 °C – 5 %, 100 °C – 10 %, 150 °C – 20 %.

Notice:

Maximum care has been taken compiling this catalogue based on many years of experience.

However we must point out, that all catalogue data is only valid, if it was expressly confirmed in the individual order. We cannot guarantee the veracity of the data and the introductions in individual cases due to the large variety of applications for WEH products, and the unknown parameters and conditions of use. We have to refer to the individual order.

The limits of use for pressure, temperature etc. in this catalogue are theoretical data calculated on the basis of tests. Because of different operating conditions we cannot guarantee that the data do accord with the special use of the client. It has to be considered, that in the practical use interactive interferences of data parameters can cause the change of the maximum values. Especially if the operating conditions are extreme, the WEH Company must be consulted before the use of the products.

Therefore the requested values should be stated in the individual order, especially for extreme operating conditions.

Furthermore we point out, that we cannot guarantee for misprints, uncompleted data or misinterpretation. The illustration of the products is for demonstration only.

The exact form and design of the product is only defined by the individual order. The brochure is only an integral part of the contract, if it is agreed expressly. Dimensions and other technical data in this catalogue are without obligation.

Technical Information

Temperature ranges:

Standard range:
+5 °C up to +80 °C,
special range: -100 °C up to +200 °C

The temperatures stated as standard cover most common applications. The seal material used has higher or lower temperature limits dependant on material (e.g. NBR -30 °C up to +100 °C, FKM -20 °C up to +200 °C, EPDM -40 °C up to +150 °C).

Under such extreme temperature conditions the suitability of WEH products to the application has to be checked specifically. If necessary, we can develop special solutions.

Seals:

The seal materials are stated with each type. For seals that are not being directly exposed to the media - NBR is used, if not otherwise stated.

Seal material	suited for	Note
NBR (e.g. Perbunan)	Mineral oils, air, water	Not for water over 80 °C!
FPM, FKM	Mineral oils, petrol, super petrol, diesel oils, air	
EPDM	Hot water, steam, brake fluid	Not resistant for mineral oils!
Urethane	Mineral oils, air	Not for water over 50 °C

This list only contains a small selection of suitable media. If your media is not listed, please contact us. Other seal materials can be specified on request.

Conversion table of temperature ranges:

Unit abbreviation	Conversion to K	Conversion to °C	Conversion to °F	Conversion to °R
Kelvin (K)	1	Kelvin temperature - 273.15	(Kelvin temperature - 273.15) x 1.8 + 32	Kelvin temperature x 1.8
Celsius (°C)	Celsius temperature + 273.15	1	(Celsius temperature x 1.8) + 32	(Celsius temperature + 273.15) x 1.8
Fahrenheit (°F)	(Fahrenheit temperature - 32) x 5/9 + 273.15	(Fahrenheit temperature - 32) x 5/9	1	Fahrenheit temperature + 459.67
Rankine (°R)	Rankine temperature x 5/9	Rankine temperature x 5/9 - 273.15	Rankine temperature - 459.67	1