

Series BLK Oil - air cooler



- maintenance friendly design
- compact dimensions
- low noise emissions
- broad performance range
- rugged cooling matrix
- comprehensive accessories

Why coolers?

There are basically two main concepts in the development of fluid power systems. One is to design systems without any cooler and if the operational conditions show in practice that the system needs a cooler to install it later. This however requires compromises that usually result in financial overspend.

The other concept recognises that a system originally designed with an integrated cooler can be designed more compactly, needs less installation space and runs more reliably due to the stabilized temperature of the fluid.

Why Bühler?

Today's requirements for an oil/air cooler demand for an effective and compact design with low noise emission and very easy maintenance.

The development of the new BLK series is based on over 30 years of experience in design and sales of air/oil-coolers. In particular the fatigue life of the cooling matrix was highlighted in the development as the matrix has to withstand pressure peaks in the return line.

Due to the exposure to the various ambient conditions air/oil cooler matrixes inevitably require some maintenance. Therefore the cooling matrix can be easily separated from the fan case without the need to dismantle the ventilator or motor or any other parts.

If our comprehensive standard range of products does not have an answer for your application we will be pleased to find special solutions for your application.

The data contained in this leaflet is sufficient to determine the right cooler for your application. However, we can offer you a computer program which makes this sizing easier for you.



BNK



BNF, BKF

Description

The BLK series consist of the following components:

- cooler matrix
- fan case with mounting feet
- fan motor assembly consisting of AC motor, fan and finger guard

The cooling matrix and fan can be separated from the fan case individually without the need to dismantle other components.

The cooling matrix of the BLK series is made from aluminium. The matrix is suitable for use with hydraulic fluids (also return lines) but is not suitable for clean water or water based fluids.

The cooling matrix can be equipped with by-pass valves of different configurations (see type code).

Please pay attention to the chapter installation.

Depending on the application or due to system requirements, off line filtration is often the appropriate solution. We recommend in these cases that you combine this off line circuit with an off line cooler. Suitable units can be found in our BNK series. These units are also suitable for the upgrade of existing systems.

Sizing the right cooler

The determination of a cooler follows two steps:

- determination of cooler size
- determination of expected pressure loss

Nomenclature

t_{0E} [°C]	inlet oil temperature
t_{LE} [°C]	inlet air temperature
ETD [K]	temperature differential: $ETD = t_{0E} - t_{LE}$
P_{spez} [kW / K]	specific cooling performance (see performance curves) $P_{spez} = P / ETD$
P [kW]	cooling performance in kW
Q [l/min]	oil flow rate
C_{oi} [kJ/kgK]	specific heat capacity of oil (approx. 2,0 kJ / kgK)
[kg/dm ³]	specific gravity of oil 0,9 kg/dm ³

Calculation sample:

assumptions:

tank capacity	(V)	ca. 200 l
start up temperature of oil	(T ₁)	15 °C
The oil is heated up approx. 25 minutes to	(T ₂)	45 °C
required oil temperature	(t _{0E})	60 °C
inlet air temperature	(t _{LE})	30 °C
oil flow rate	(Q)	80 l/min

Pressure loss curves determined with an average viscosity of 30 cSt

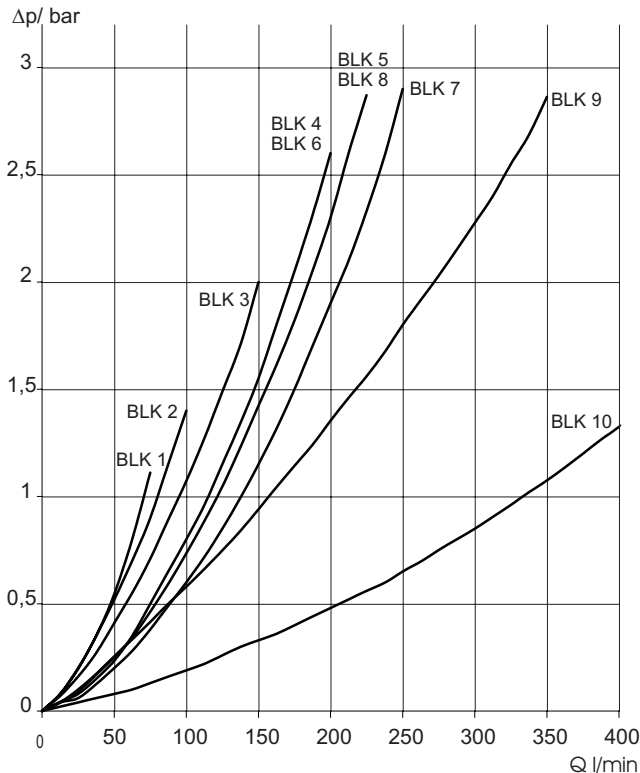

Attention: If the coolers are used in open air or the oil has even higher viscosity the installation of by-pass valves may be necessary. Please check the section "functions schemes".

Calculation

1. calculation of P

$$P = \frac{200 \times 0,9 \times 2,0 \times (45-15)}{25 \times 60} = 7,2 \text{ kW}$$

2. $ETD = t_{0E} - t_{LE} = 60^\circ\text{C} - 30^\circ\text{C} = 30 \text{ K}$

3. required specific performance:

$$P_{spez} = P / ETD = 7,2 \text{ kW} / 30 \text{ K} = 0,24 \text{ kW/K}$$

4. choose in curve at 80 l/min a cooler with:

$$P_{spez} 0,24 \text{ kW/K:}$$

There are two possibility's:

BLK 2.2 or alternatively BLK 3.4 this cooler is larger but has the lower noise emission

Temperature/viscosity table

Type of oil	at 50°C	at 60°C	at 70°C	
VG 16	9,4	5,6	3,3	cSt
VG 22	15	11	8	cSt
VG 32	21	15	11	cSt
VG 46	29	20	14	cSt
VG 68	43	29	20	cSt
VG 120	68	44	31	cSt
VG 220	126	77	51	cSt
VG 320	180	108	69	cSt

Correction factor k(visc)

viscosity (cSt)	k(visc)	viscosity (cSt)	k(visc)
10	0,6	60	1,6
20	0,8	80	2,1
30	1,0	100	2,7
40	1,2	150	4,2
50	1,4		

Determine of real pressure loss:

1. select in graph the Δp at Q of a chosen cooler type
2. determine real viscosity from temperature/viscosity table
3. take correction factor k(visc) according to real viscosity and multiply with Δp in bar

Performance curves BLK size 1 to 6

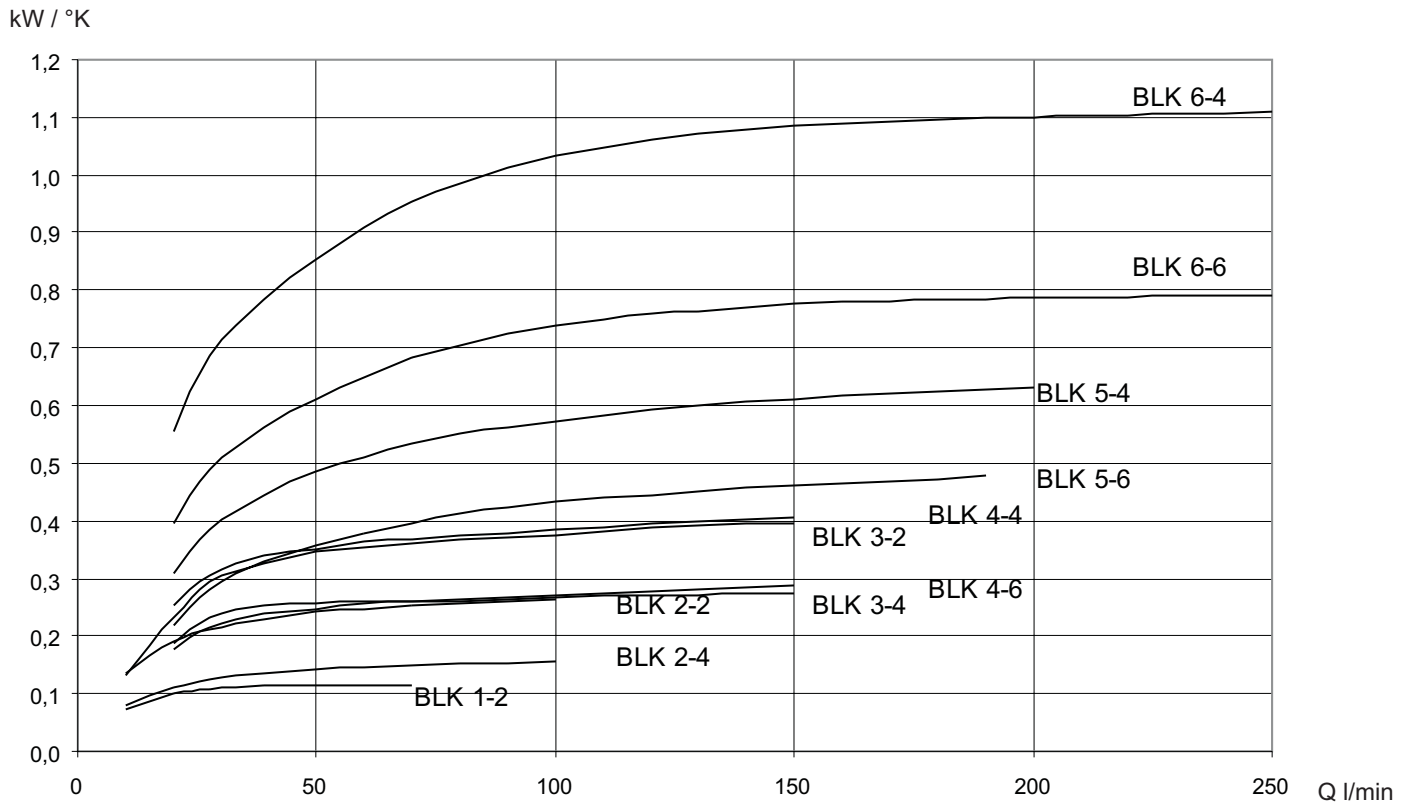

Performance curves BLK size 7 to 10

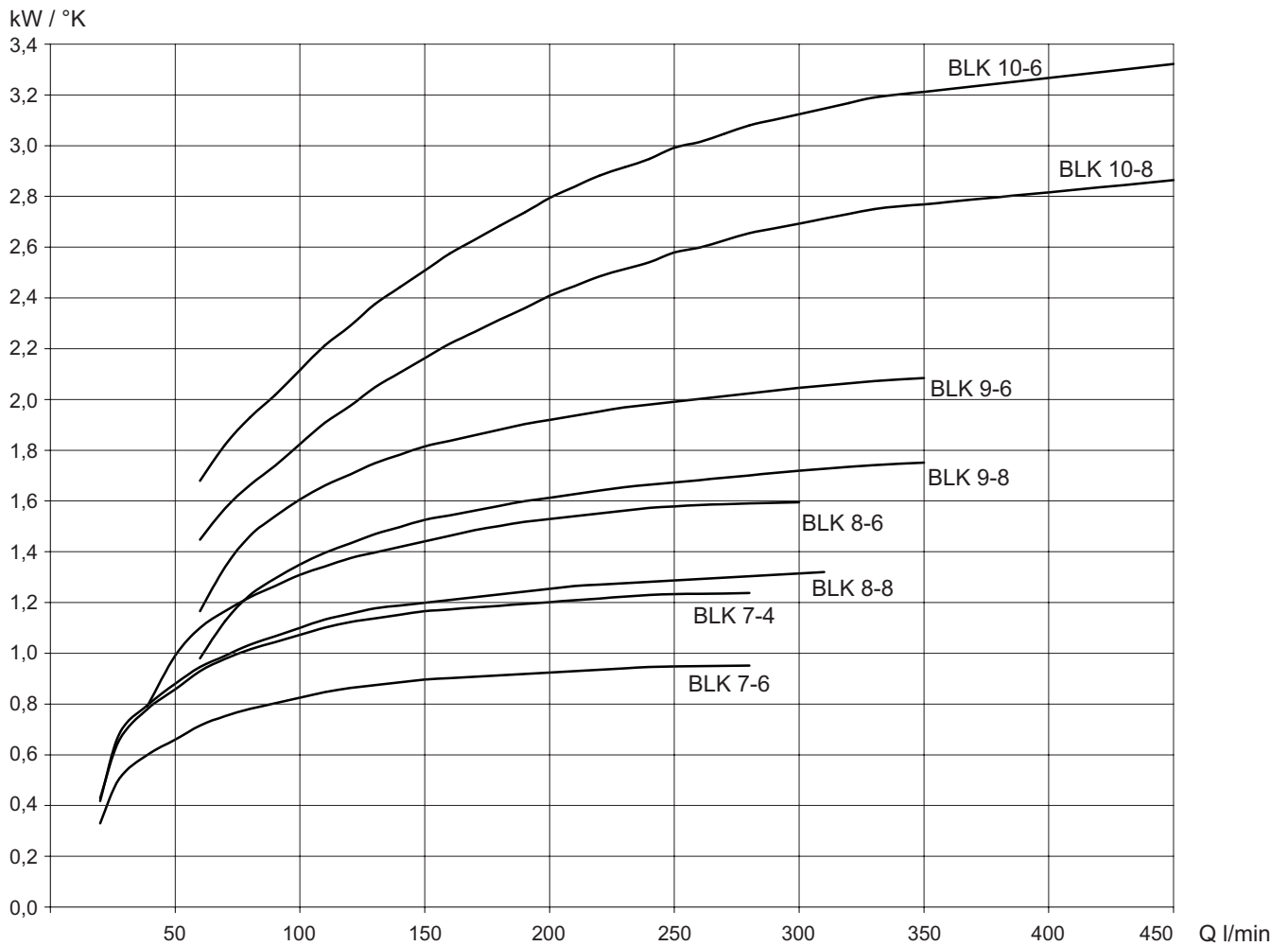

General data

material / surface protection

cooling matrix: aluminium, varnished
fan case, finger guard and motor console: mild steel powder coated

colour
RAL 7001

fluids

mineral oil according to DIN 51524
oil/water emulsion HFA and HFB according to CETOP RP 77 H
water glycol HFC according to CETOP RF 77 H
phosphate ester HFD-R according to CETOP RP 77 H

Operating pressure

static: max. 21 bar

operating temperature

media: max. 120°C

max. viscosity

100 cSt average viscosity, higher viscosities upon request

electrical motors:

(others on demand):
voltage:
BLK 1.2 230 V 50Hz
BLK 2.2 - BLK 10.8 230 / 400 V 50Hz ± 5%
276 / 480 V 60Hz ± 5%

insulation class: F

rise in temperature: B

protection class: IP 55

design according to: IEC 34-1, IEC 72-1, DIN 57530, VDE 0530

Basic datas

part no.	type	motor power output	full load current at 400V	motor poles	weight (kg)	volume (l)	noise emission db(A)*
3501200	BLK 1.2	0,25 kW	/ 0,24A 230V	2	7	0,8	65
3502200	BLK 2.2	0,55 kW	/ 1,54 A	2	23	1,3	81
3502400	BLK 2.4	0,25 kW	/ 0,94 A	4	23	1,3	66
3503200	BLK 3.2	1,1 kW	/ 2,64 A	2	31	1,8	87
3503400	BLK 3.4	0,25 kW	/ 0,94 A	4	28	1,8	71
3504400	BLK 4.4	0,37 kW	/ 1,12 A	4	34	2,3	73
3504600	BLK 4.6	0,18 kW	/ 0,80 A	6	34	2,3	63
3505400	BLK 5.4	0,75 kW	/ 1,99 A	4	45	3,1	79
3505600	BLK 5.6	0,25 kW	/ 1,09 A	6	42	3,1	68
3506410	BLK 6.4	2,2 kW	/ 5,12 A	4	77	4,1	86
3506610	BLK 6.6	0,55 kW	/ 1,85 A	6	60	4,1	74
3507410	BLK 7.4	2,2 kW	/ 5,12 A	4	87	5,4	89
3507610	BLK 7.6	0,55 kW	/ 1,85 A	6	72	5,4	75
3508610	BLK 8.6	1,5 kW	/ 3,88 A	6	95	6,3	79
3508810	BLK 8.8	0,55 kW	/ 2,10 A	8	91	6,3	73
3509610	BLK 9.6	2,2 kW	/ 5,48 A	6	159	8,2	86
3509810	BLK 9.8	1,1 kW	/ 3,52 A	8	155	8,2	79
3510610	BLK 10.6	5,5 kW	/ 12,60 A	6	256	19	90
3510810	BLK 10.8	2,2 kW	/ 6,05 A	8	241	19	84

The part numbers for BLK 2 -5 are 50/60 Hz versions, for BLK 6-10 the 50 cycle versions only, the 60 cycle versions are available upon request.

* DIN EN ISO 3744, class 3

Type code

BLK 4 . 6- IBx - T50

number of poles (see table 1)
size (see table 1)

BLK 4 . 6- IBx - T50

If the by-pass valve or if the temperature switch are needed the following codes have to be added:

by-pass version

AB
IB
ITB
ATB
x

external by-pass
integrated by-pass
integrated temperature operated by-pass 2 bar / 45°C
external temperature operated by-pass 2 bar / 45°C
by-pass pressure **2; 5 or 8 bar**

temperature switch

T50, T60
T70, T80

figures stand for °C, details see data sheet

Dimensions

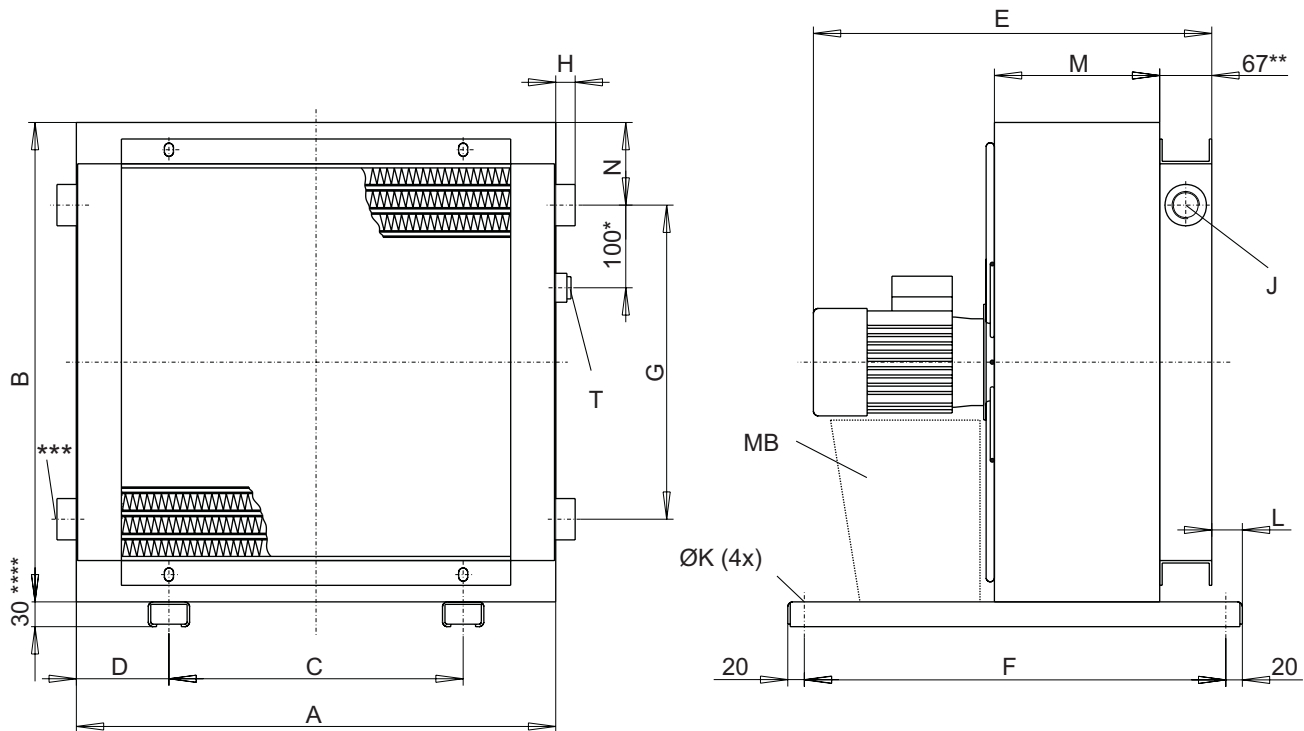

- MB some types have consoles to support motor
 T connection G ½ for temperature switch
 connection M14 x1,5 for temperature switch BLK 1
 * BLK 9 and 10 = 150 mm
 ** BLK 1 = 45 mm
 BLK 10 = 94 mm
 *** connection only at BLK 9 and 10
 **** BLK 1 = 20 mm

cooler type	A	B	C	D	E	F	G	H	J	K	L	M	N	MB
BLK 1.2	315	237	190	62,5	144	165	-	-	2x G1/2	7	20	50	25	-
BLK 2.2	370	370	203	83,5	406	510	-	25	2x G1	9	33	125	106	-
BLK 2.4	370	370	203	83,5	406	510	-	25	2x G1	9	33	125	106	-
BLK 3.2	440	440	203	118,5	431	510	230	25	3x G1	9	33	150	105	-
BLK 3.4	440	440	203	118,5	453	510	230	25	3x G1	9	37	150	105	-
BLK 4.4	500	500	203	148,5	456	510	230	25	3x G1	9	37	175	104	-
BLK 4.6	500	500	203	148,5	456	510	230	25	3x G1	9	37	175	104	-
BLK 5.4	580	580	356	112	505	510	305	26,5	3x G1	9	37	200	100	-
BLK 5.6	580	580	356	112	483	510	305	26,5	3x G1	9	37	200	100	-
BLK 6.4	700	700	356	172	609	510	410	9,5	3x G1 1/4	9	37	225	110	x
BLK 6.6	700	700	356	172	530	510	410	9,5	3x G1 1/4	9	37	225	110	x
BLK 7.4	700	840	356	172	634	510	590	9,5	3x G1 1/4	9	37	250	91	x
BLK 7.6	700	840	356	172	555	510	590	9,5	3x G1 1/4	9	37	250	91	x
BLK 8.6	870	870	508	181	643	890	585	11	3x G1 1/4	12	50	275	101,5	x
BLK 8.8	870	870	508	181	618	890	585	11	3x G1 1/4	12	50	275	101,5	x
BLK 9.6	1010	1020	518	246	699	890	822	3	4x G1 1/2	12	73	300	99	x
BLK 9.8	1010	1020	518	246	682	890	822	3	4x G1 1/2	12	73	300	99	x
BLK 10.6	1185	1185	600	242,5	836	910	940	5	4x SAE 2 1/2"	12	73	325	130	x
BLK 10.8	1185	1185	600	242,5	798	910	940	5	4x SAE 2 1/2"	12	73	325	130	x

connection BLK 10 = SAE 2 ½" flange - 3000 psi

Function schemes

Standard BLK 2

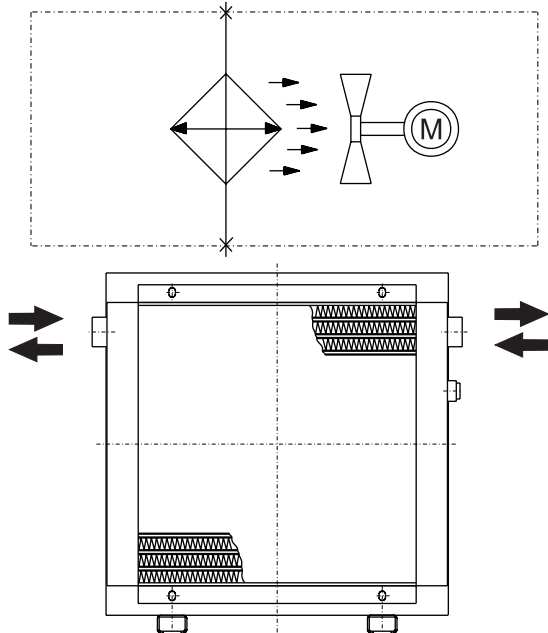

Flow direction optional from left to right or vice versa.

Standard BLK 1/3 to BLK 10

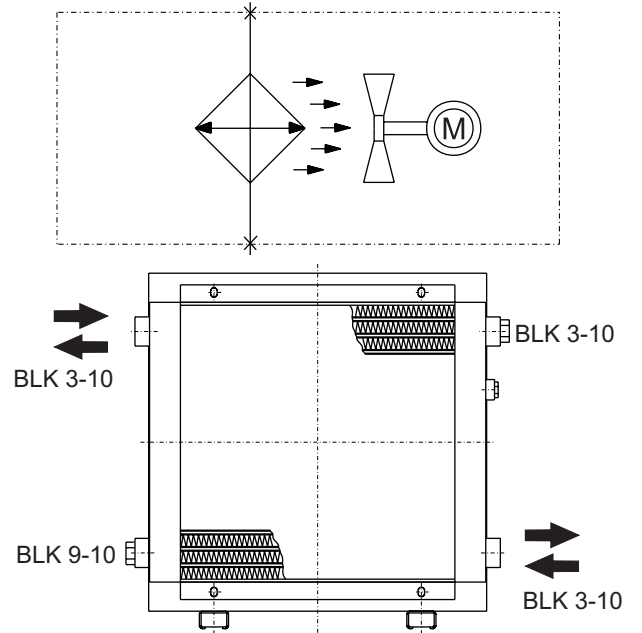

Flow direction optional from high left to low right or vice versa. Other ports must be plugged.

Internal by-pass IB/ITB (BLK 3-10)

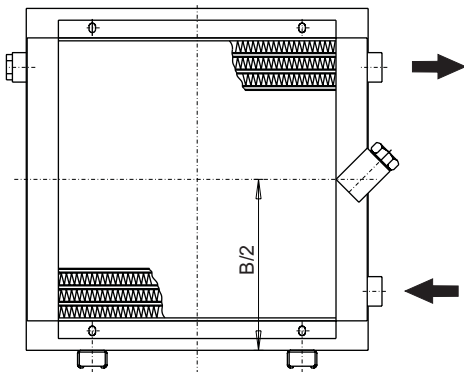

Oil inlet and outlet are always at the same side. Ports on opposite side must be plugged.

with by-pass valve

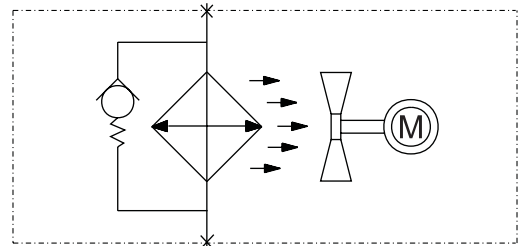

with temperature operated by-pass valve

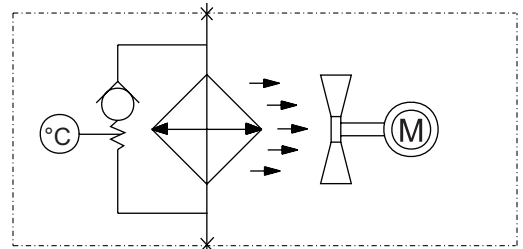

External by-pass AB/ATB (BLK 2-10)

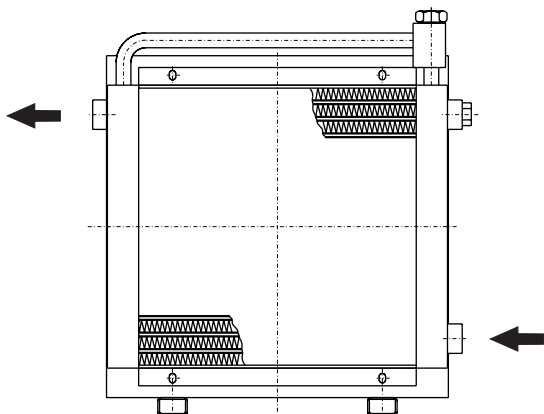

Oil inlet is always from low port, outlet on opposite side. Other ports must be plugged.

with temperature switch

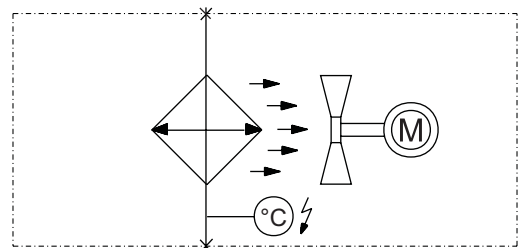

Installation

Location

The cooler must be located in such a way that the air flowing through the matrix has free flow on entry and exit. The distance between air intake or air outlet to the nearest surrounding obstacle should be a minimum of half the height of the matrix (dimension B). Free air flow must be provided. If the cooler is to be sited near to working personnel the effect of hot draught and noise emissions must be taken into account.

If the ambient air is carrying impurities or other particulates the cooling matrix could become clogged quite quickly thus reducing the cooling efficiency. If this situation is unavoidable we recommend cleaning the matrix on a regular basis (see operation manual).

If the cooler is located in open air the motors must be weather shielded.

Always provide good accessibility for inspection or maintenance.

Mounting

The BLK's are mounted with four bolts through their mounting feet to an adequate support structure. The cooler can be mounted over head or to walls with no restriction.

Connection of oil circuit

The connections from the cooler to the system should be stress and vibration free. The use of flexible hoses is highly recommended. Please comply with local safety requirements and avoid any risk to the environment from oil spills etc.

The series BLK is a product designed by BÜHLER company

The company

BÜHLER MESS- UND REGELTECHNIK GmbH, Ratingen was founded in 1969.

BÜHLER's corporate philosophy is to offer products and solutions representative of the state of the art.

BÜHLER also specialises in producing level and temperature measuring equipment, particularly for the fluid power industry.



The products

Our commitment to customers has given rise to a production program which comprises specialized products for fluid technology.

Although these products were initially developed entirely as specials many of them have now become industry standards.

Bühler quality

Bühler has achieved accreditation from Lloyd's register to be in compliance with ISO 9001 and therefore consider it our obligation to offer our customers not only excellent products, but also the best service possible.