

Oil / water cooler Series BWT

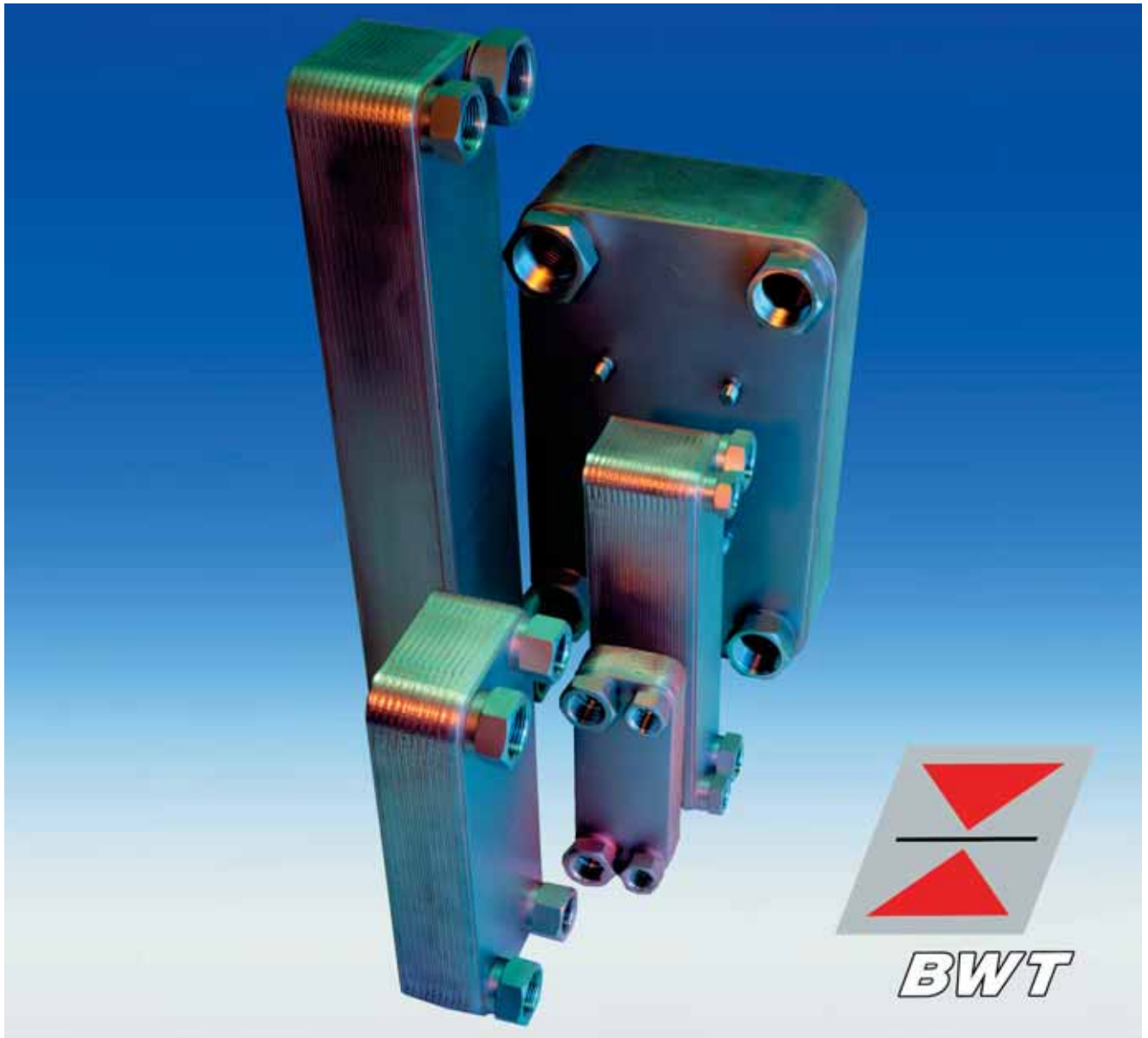

- high exchange efficiency
- equally distributed turbulent flow
- little installation space required
- high fatigue life
- low water consumption
- maintenance free
- broad temperature range
- easy installation

Why coolers?

There are basically two main concepts in the development of fluid power systems. One is to design systems minus a cooler and if the operational conditions show in practice that the system needs a cooler to install it later.

This however requires compromises that usually result in financial overspend.

The other concept recognises that a system originally designed with an integrated cooler can be built more compactly, needs less installation space and runs more reliably due to the stabilized temperature of the fluid.

Why Bühler?

Since water is becoming a precious resource, significantly reduced water consumption is favoured by the system designers. After over 25 years experience in design and sales of traditional tube and shell heat exchangers Bühler recognised that a new concept was required to meet the increasing demand for water conservation.

The plate heat exchanger fulfills this requirement particularly for the fluid power market.

In cooperation with a well reputed international manufacturer of plate heat exchangers Bühler has developed a comprehensive range of braced plate coolers specifically for fluid power applications. Bühler has been offering this new concept of oil / water coolers now for over five years with increasing recognition and success.

If our comprehensive standard range of products does not have an answer for your application we will be pleased to find special solutions for your application.

The data contained in this leaflet is sufficient to determine the right cooler for your application. However, we can offer you a computer program which makes this sizing easier.



Description

The BWT oil / water coolers consist of a number of profiled stainless steel plates. The direction of the profile is reversed on every other plate so that the ridges on adjacent plates intersect with another forming a network of contact points. The subsequent brazing process creates a very compact and pressure resistant package, which virtually utilizes all material for heat transfer.

Compared with traditional systems the complex geometry of the BWT plate cooler provides a highly turbulent flow with very equal distribution resulting in an outstanding heat transfer efficiency. Even at lower velocities a turbulent flow is insured which is constantly changing direction due to the profile and thus disturbing the boundary layer. BWT plate coolers are much less prone to fouling than coolers of traditional design thanks to the smooth surface quality of the cooler plates and the turbulent flow. Experience shows that fouling is not a problem in plate coolers providing the application parameters have been indicated correctly.



Cooling performance of different BWT types

cooling performance in KW

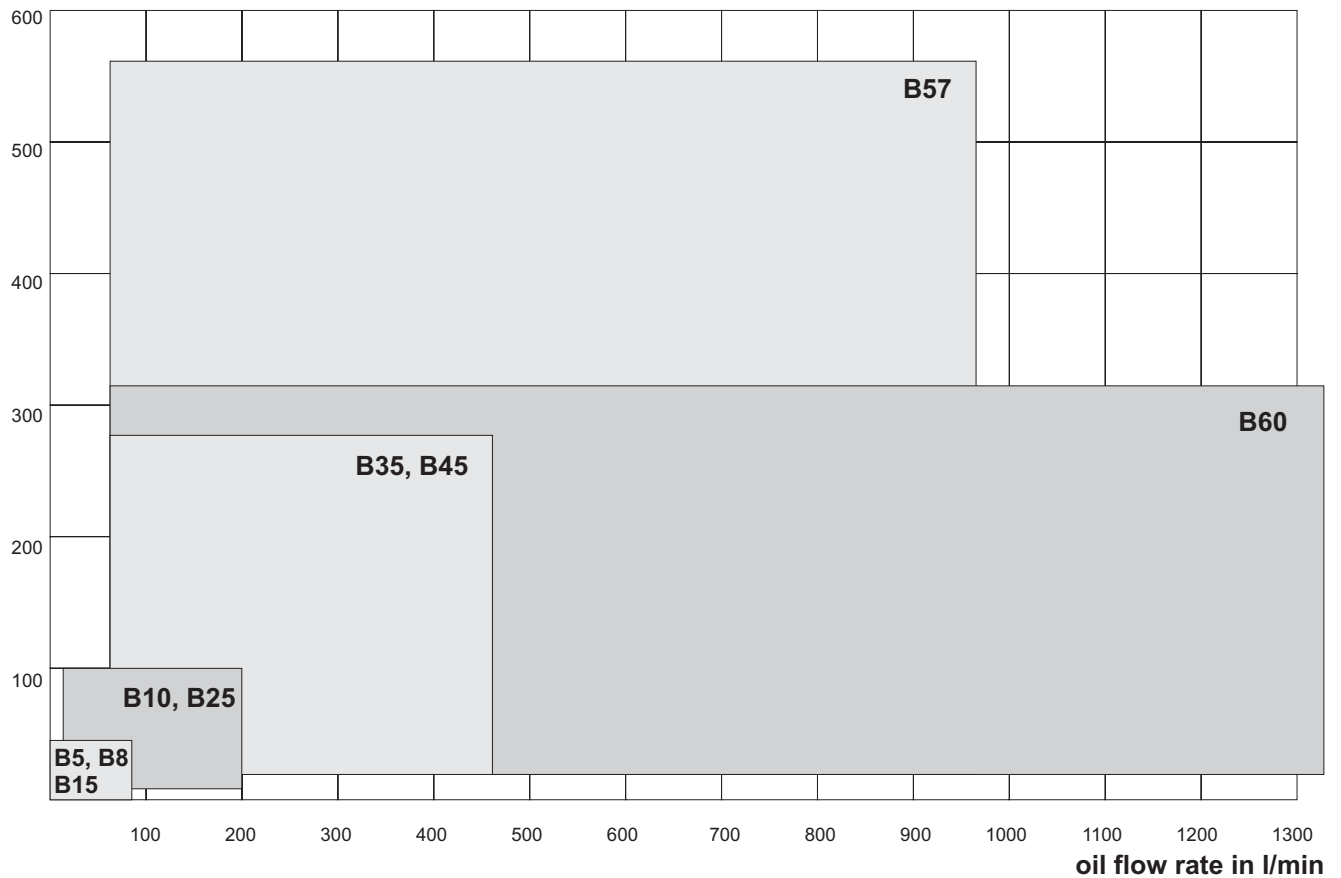

The diagram shows the range of performance of the different basic types.

For a more precise calculation we can provide a computer program which is available upon request.

Approvals

BWT plate coolers are approved by the following authorities:

Sweden	Statens Anläggningsprovning (SA)
Norway	Kjelkontrollen
Canada	Canadian Standard Association (CSA)
Germany	Technischer Überwachungsverein (TÜV)
USA	Underwriters Laboratories (UL)
Finland	Teknillinen Tarkastuskeskus (TK)
Switzerland	Schweizerischer Verein des Gase- und Wasserfaches (SVDB)
EU	TRB801 No. 25

Bühler is ISO 9001 certified

General data

material	stainless steel 1.4401, Cu 99,9% and Cu free braze material
operating pressure	
static:	30 bar
dynamic:	5 mio cycles at 3 Hz, 20 bar
operating temperature	+ 185°C



Technical data BWT B05, B08 and B15

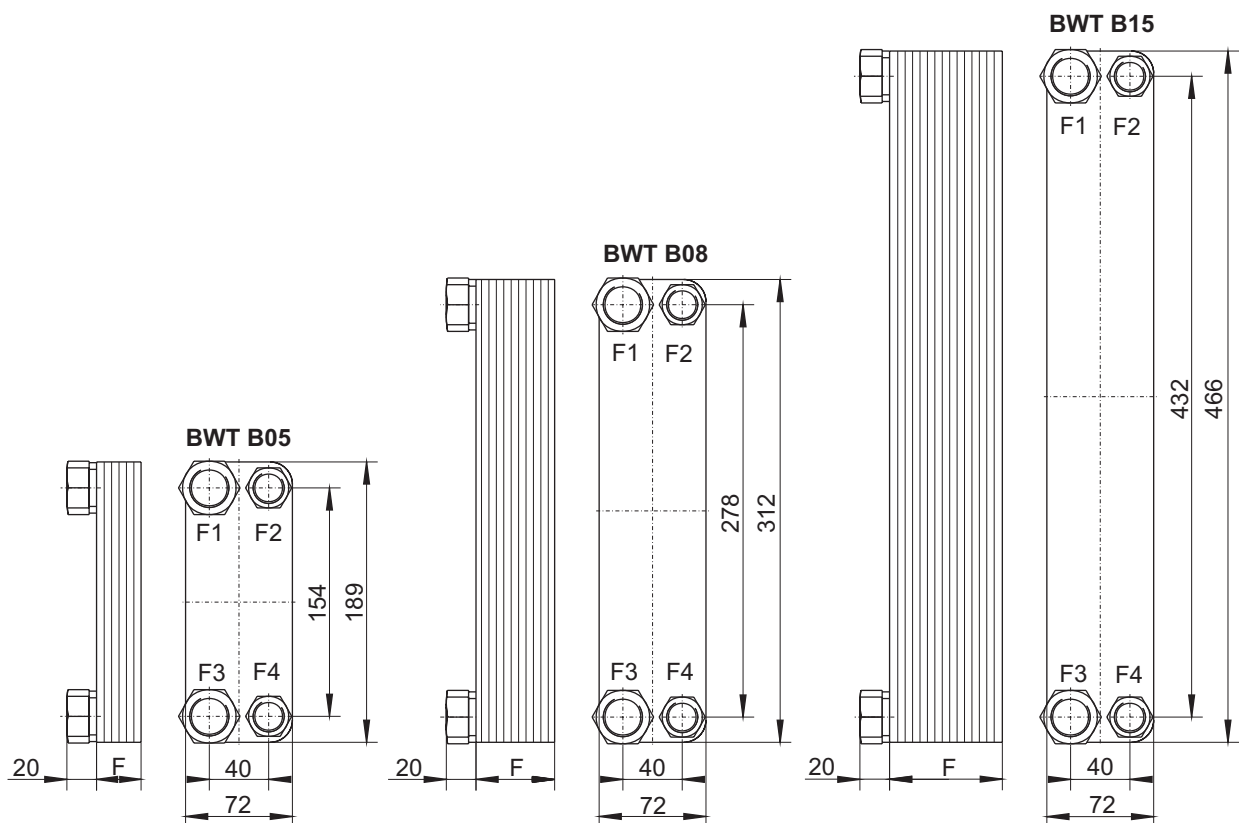

Type	Part no.	F	Cooling performance KW	Oil ports		Water ports		Weight kg netto	Volume l
				F3, F1	SW	F2, F4	SW		
BWT B05x010	3405010	30	1,5-5,0	G 3/4	36 mm	G 1/2	27 mm	1,0	0,1
BWT B05x020	3405020	53	1,5-11	G 3/4	36 mm	G 1/2	27 mm	1,5	0,2
BWT B08x010	3408010	30	2,5-6,0	G 3/4	36 mm	G 1/2	27 mm	1,6	0,5
BWT B08x020	3408020	53	5,0-16	G 3/4	36 mm	G 1/2	27 mm	2,0	1,0
BWT B08x030	3408030	76	10-25	G 3/4	36 mm	G 1/2	27 mm	3,0	1,5
BWT B15x030	3415030	76	6,0-30	G 3/4	36 mm	G 1/2	27 mm	4,0	2,0

Mounting brackets for BWT

Type	part no.	A	B
BB 05	34BB05	101	223
BB 08	34BB08	101	346
BB 15	34BB15	101	500

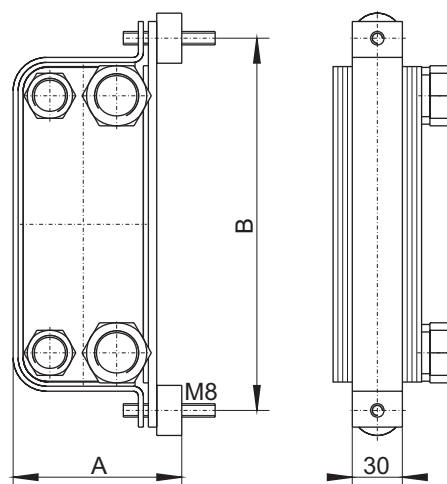

Technical data BWT B10/B12 and B25

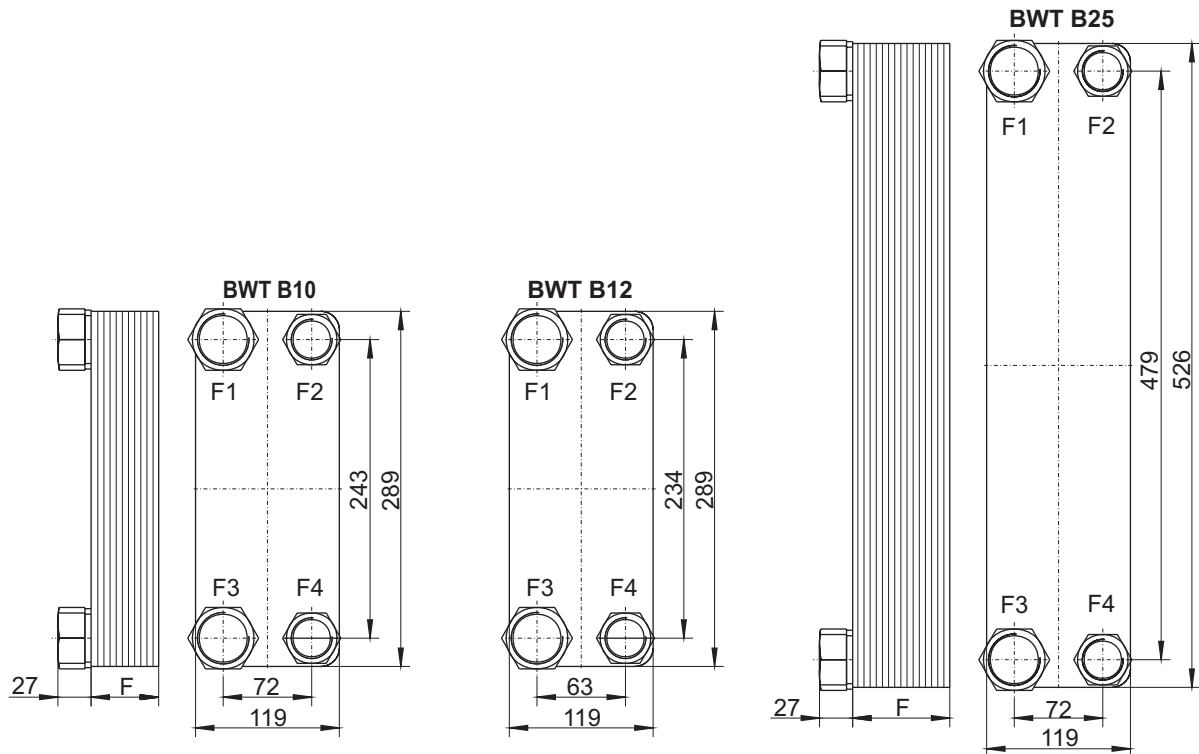

Type	Part no.	F	Cooling performance KW	Oil ports		Water ports		Weight kg netto	Volume l
				F3, F1	SW	F2, F4	SW		
BWT B10x020	3410020	49	5-25	G 1	41 mm	G $\frac{3}{4}$	36 mm	4.0	1.0
BWT B10x030	3410030	72	10-40	G 1	41 mm	G $\frac{3}{4}$	36 mm	5.0	1.5
BWT B10x040	3410040	94	10-50	G 1	41 mm	G $\frac{3}{4}$	36 mm	7.0	2.0
BWT B10x050	3410050	116	15-60	G 1 $\frac{1}{4}$	50 mm	G 1	41 mm	8.0	3.0
BWT B10x070	3410070	161	20-65	G 1 $\frac{1}{4}$	50 mm	G 1	41 mm	10.0	3.5
BWT B10x090	3410090	206	20-80	G 1 $\frac{1}{4}$	50 mm	G 1	41 mm	13.0	4.0
BWT B12Hx060	3412060	145	35-85	G 1 $\frac{1}{4}$	50 mm	G 1	41 mm	13.0	4.0
BWT B25x030	3425030	72	13-45	G 1 $\frac{1}{4}$	50 mm	G 1	41 mm	10.0	2.0
BWT B25x040	3425040	94	13-65	G 1 $\frac{1}{4}$	50 mm	G 1	41 mm	12.0	3.0
BWT B25x060	3425060	139	20-90	G 1 $\frac{1}{4}$	50 mm	G 1	41 mm	17.0	5.0
BWT B25x080	3425080	184	25-105	G 1 $\frac{1}{4}$	50 mm	G 1	41 mm	21.0	7.0

Mounting brackets for BWT

type	part no.	A	B
BB 10	34BB10	146	323
BB 25	34BB25	146	558

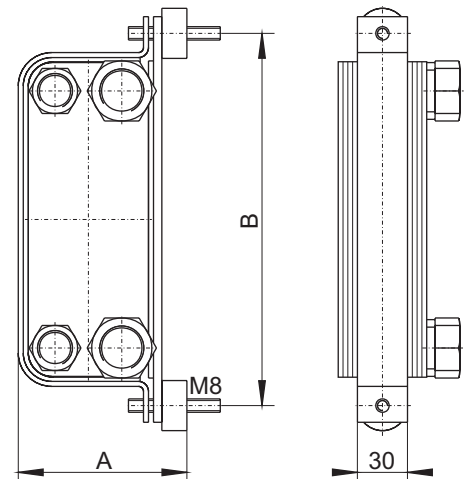

Technical data BWT B35 and B45

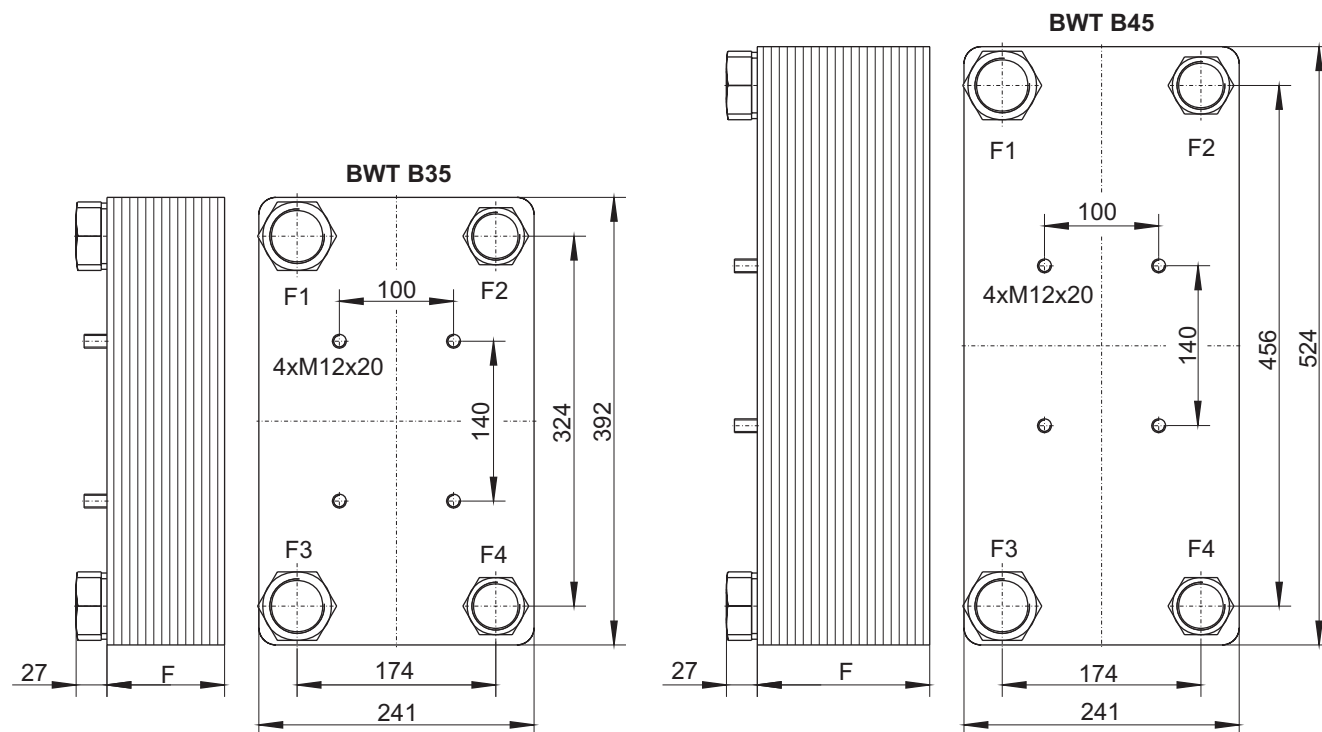

Type	Part no.	F	Cooling performance KW	Oil ports		Water ports		Weight kg netto	Volume l
				F3, F1	SW	F2, F4	SW		
BWT B35x040	3435040	103	30-105	G 1 1/2	60 mm	G 1 1/4	50 mm	18,0	5,0
BWT B35x050	3435050	127	55-145	G 1 1/2	60 mm	G 1 1/4	50 mm	21,0	7,0
BWT B35x060	3435060	151	55-155	G 1 1/2	60 mm	G 1 1/4	50 mm	24,0	8,0
BWT B35x090	3435090	223	55-175	G 1 1/2	60 mm	G 1 1/4	50 mm	34,0	12,0
BWT B45x040	3445040	103	40-125	G 1 1/2	60 mm	G 1 1/4	50 mm	23,0	6,0
BWT B45x060	3445060	151	55-190	G 1 1/2	60 mm	G 1 1/4	50 mm	31,0	10,0
BWT B45x080	3445080	199	65-245	G 1 1/2	60 mm	G 1 1/4	50 mm	40,0	14,0
BWT B45x120	3445120	295	135-280	G 1 1/2	60 mm	G 1 1/4	50 mm	57,0	21,0

Mounting brackets for BWT

type	part no	A	B
BB 35	34BB35	270	426
BB 45	34BB45	270	558

We recommend to use two brackets for the types B35-090 and B45-060 up to B45-120

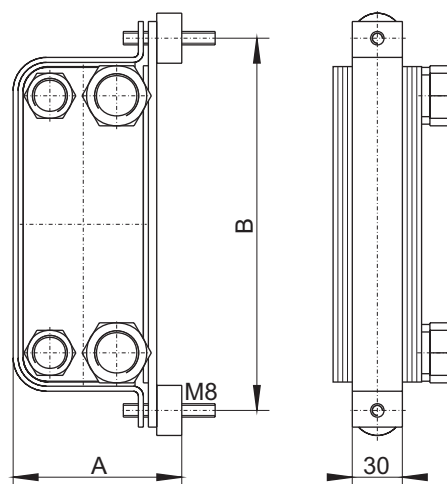

Technical data BWT B57 and B60

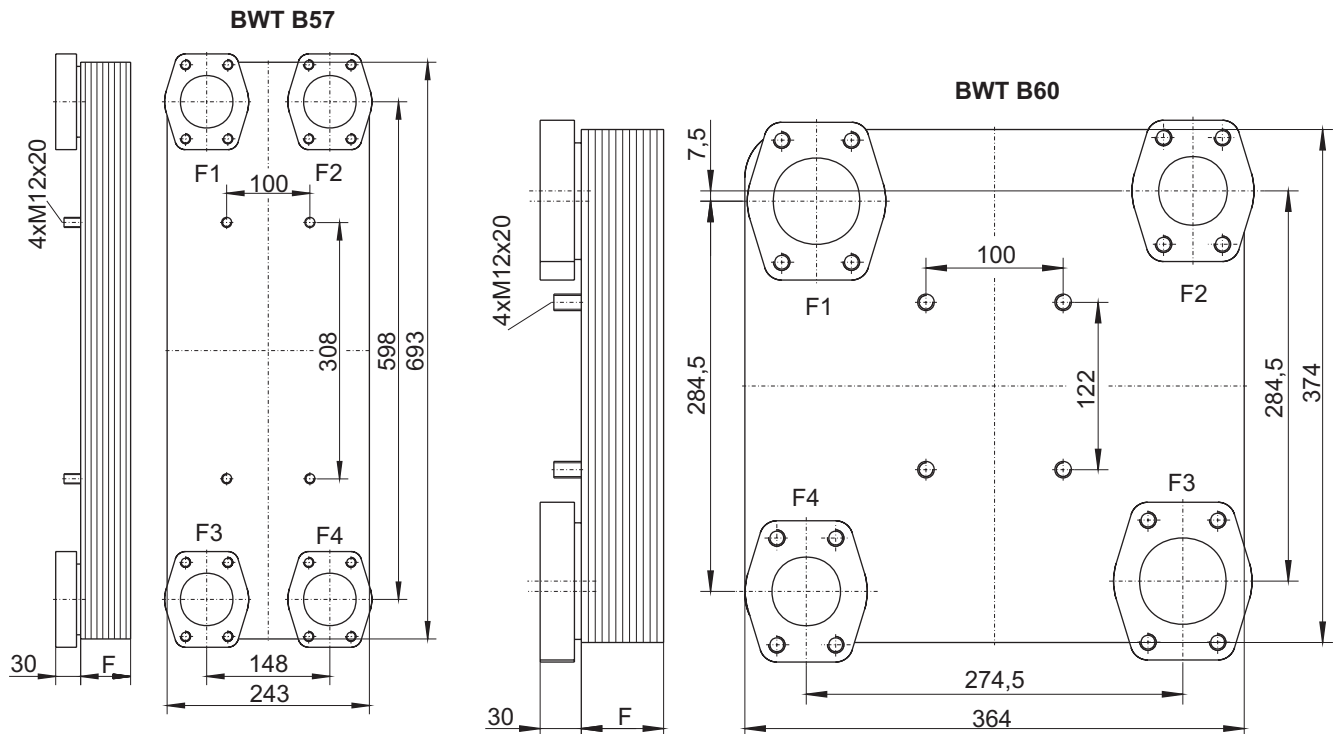

Type	Part no.	F	Cooling performance KW	Oil ports F3, F1	Water ports F2, F4	Weight kg netto	Volume l
BWT B57x040	3457040	113	39-160	SAE 2 ½ *	SAE 2 ½	39	13
BWT B57x060	3457060	162	74-232	SAE 2 ½ *	SAE 2 ½	50	20
BWT B57x080	3457080	211	79-327	SAE 2 ½ *	SAE 2 ½	61	26
BWT B57x100	3457100	259	84-424	SAE 2 ½ *	SAE 2 ½	73	33
BWT B57x120	3457120	308	89-494	SAE 2 ½ *	SAE 2 ½	84	40
BWT B57x140	3457140	357	93-566	SAE 2 ½ *	SAE 2 ½	95	46
BWT B60x040	3460040	104	30-113	SAE 2 ½ *	SAE 2	33	9
BWT B60x060	3460060	147	35-165	SAE 2 ½ *	SAE 2	42	13
BWT B60x080	3460080	190	40-216	SAE 2 ½ *	SAE 2	52	17
BWT B60x100	3460100	232	43-267	SAE 2 ½ *	SAE 2	61	22
BWT B60x120	3460120	275	56-301	SAE 2 ½ *	SAE 2	70	26
BWT B60x140	3460140	318	76-316	SAE 2 ½ *	SAE 2	80	31

* SAE flanges: nominal pressure 3000 psi

Installation

The BWT plate cooler should be located to allow free access from all sides and good visibility. There are no particular installation restrictions, however the unit should be easy to drain in case of open air installation to prevent freezing.

Connection of oil and water circuits.

The connections from cooler to the system should be stress and vibration free. The use of flexible hoses or compensators is highly recommended. Please comply with local safety requirements and avoid any risk to the environment from oil spills etc.



The series BWT is a product designed by BÜHLER company

The company

BÜHLER MESS- UND REGELTECHNIK GMBH, Ratingen was founded in 1969.

BÜHLER's corporate philosophy is to offer products and solutions representative of the state of the art.

BÜHLER also specialises in producing level and temperature measuring equipment, particularly for the fluid power industry.

The products

Our commitment to customers has given rise to a production program which comprises specialized products for fluid technology.

Although these products were initially developed entirely as specials many of them have now become industry standards.

Bühler quality

Bühler has achieved accreditation from Lloyd's register to be in compliance with ISO 9001 and therefore consider it